

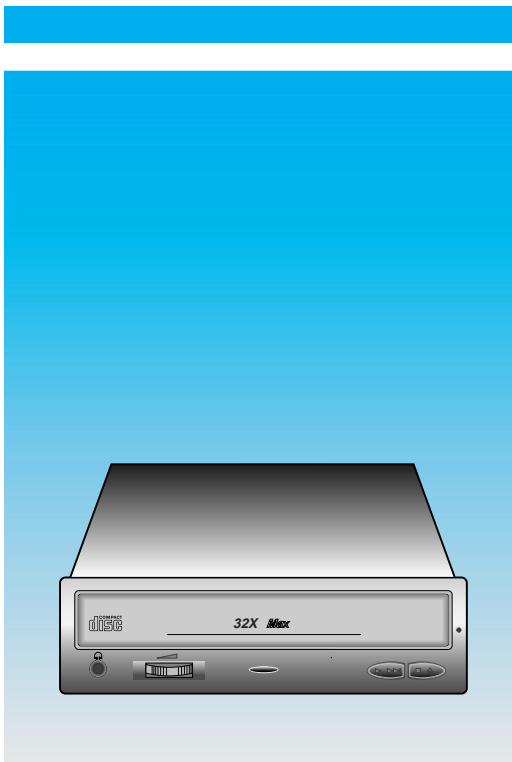

Model:SCR-3232

CD-ROM service *manual*

CONTENTS



- Specifications
- Cautions at Service
- External Part Name
- Disassembly Method
- Exploded Views
- Device Part List
- Packing Options
- Operational Position Diagram
- CD-ROM Block Diagram
- Troubleshooting
- Circuit Diagram
- Main Components Block Diagram & Pin Descriptions
- Electrical Parts List

❖ The design and part of this product is subject to change without prior notice for performance improvement.



© Samsung Electronics Co., Ltd.
JULY, 1998
Printed in Korea

■ Specifications

1. General Specifications

- Drive type : Computer built-in
- Power consumption : DC + 5V, 1A
DC + 12V, 1.5A
- Dimensions : 149mm(W)X41.5mm(L)X202.6mm(H)
- Net Weight : 950g

2. Electrical Features

- Interface : ATAPI BUS(IDE)
- Data transfer rate 4800KByte/Sec MAX
(2400KByte/Sec AVG.)
- ACCESS TIME : 1/3 stroke : Below 120msec
full stroke : Below 190msec
- Buffer Capacity : 512Kbyte
- Error ratio : Mode 1: Below 10^{-12}
Mode 2: Below 10^{-9}

- Frequency response : 20Hz~20KHz
- Signal to noise ratio : 75dB(1KHz, Lineout)
- Distortion factor : 0.15% Less than(1KHz)
- Channel separation : 65dB(1KHz, Lineout)
- Signal output level : LINEOUT : 0.7 Vrms($\pm 20\%$)
H/PHONE: 0.6 Vrms($\pm 20\%$)
- Used laser : Semiconductor laser

■ Cautions at Service

1. General Items

- 1) Be careful not to have your eyes or a part of body touch with laser diode at repair because this product uses laser diode.
- 2) Do not disassemble Pick-up at repair. If the laser diode is bad, replace the entire Pick-up.
- 3) Keep away from TV or other electrical units at repair to prevent influence from surrounding units.
- 4) If you replace the parts during repair, be sure to unplug the power cable before replacement.
- 5) If you insert a disc into the drive, be sure to load it correctly.
- 6) Because this unit can't be used by itself, surely mount it on PC (486 DMA support) and check the operations in use of private device driver floppy diskette. Refer to Instruction manual.
- 7) This unit has many parts with features related to safety and especially, for essential parts, the importance is indicated on circuit diagram and part list.
Be certain to use the parts with same specifications at replacing these parts.

2. Earthing cautions at handling Pick-up

- Because the laser diode in optical Pick-up is subject to get out of order due to the potential difference occurring by electricity load charged in clothes or bodies, observe the following earthing items at handling.
- 1) Body earthing(hand) : Be sure to wear a wrist strip with one side earthed.(Impedance : Below 104).
It removes the electricity formed in body.
 - 2) Work table earthing : Put the earthed conductive plate(Impedance : Below 104) such as copper plate on work table.
 - 3) Cautions for clothes : Do not have any clothes touch with Pick-up because the electricity formed in clothes is destroyed easily.

■ Specifications

1. General Specifications

- Drive type : Computer built-in
- Power consumption : DC + 5V, 1A
DC + 12V, 1.5A
- Dimensions : 149mm(W)X41.5mm(L)X202.6mm(H)
- Net Weight : 950g

2. Electrical Features

- Interface : ATAPI BUS(IDE)
- Data transfer rate 4800KByte/Sec MAX
(2400KByte/Sec AVG.)
- ACCESS TIME : 1/3 stroke : Below 120msec
full stroke : Below 190msec
- Buffer Capacity : 512Kbyte
- Error ratio : Mode 1: Below 10^{-12}
Mode 2: Below 10^{-9}

- Frequency response : 20Hz~20KHz
- Signal to noise ratio : 75dB(1KHz, Lineout)
- Distortion factor : 0.15% Less than(1KHz)
- Channel separation : 65dB(1KHz, Lineout)
- Signal output level : LINEOUT : 0.7 Vrms($\pm 20\%$)
H/PHONE: 0.6 Vrms($\pm 20\%$)
- Used laser : Semiconductor laser

■ Cautions at Service

1. General Items

- 1) Be careful not to have your eyes or a part of body touch with laser diode at repair because this product uses laser diode.
- 2) Do not disassemble Pick-up at repair. If the laser diode is bad, replace the entire Pick-up.
- 3) Keep away from TV or other electrical units at repair to prevent influence from surrounding units.
- 4) If you replace the parts during repair, be sure to unplug the power cable before replacement.
- 5) If you insert a disc into the drive, be sure to load it correctly.
- 6) Because this unit can't be used by itself, surely mount it on PC (486 DMA support) and check the operations in use of private device driver floppy diskette. Refer to Instruction manual.
- 7) This unit has many parts with features related to safety and especially, for essential parts, the importance is indicated on circuit diagram and part list.
Be certain to use the parts with same specifications at replacing these parts.

2. Earthing cautions at handling Pick-up

- Because the laser diode in optical Pick-up is subject to get out of order due to the potential difference occurring by electricity load charged in clothes or bodies, observe the following earthing items at handling.
- 1) Body earthing(hand) : Be sure to wear a wrist strip with one side earthed.(Impedance : Below 104).
It removes the electricity formed in body.
 - 2) Work table earthing : Put the earthed conductive plate(Impedance : Below 104) such as copper plate on work table.
 - 3) Cautions for clothes : Do not have any clothes touch with Pick-up because the electricity formed in clothes is destroyed easily.

External Part Name

1.Front

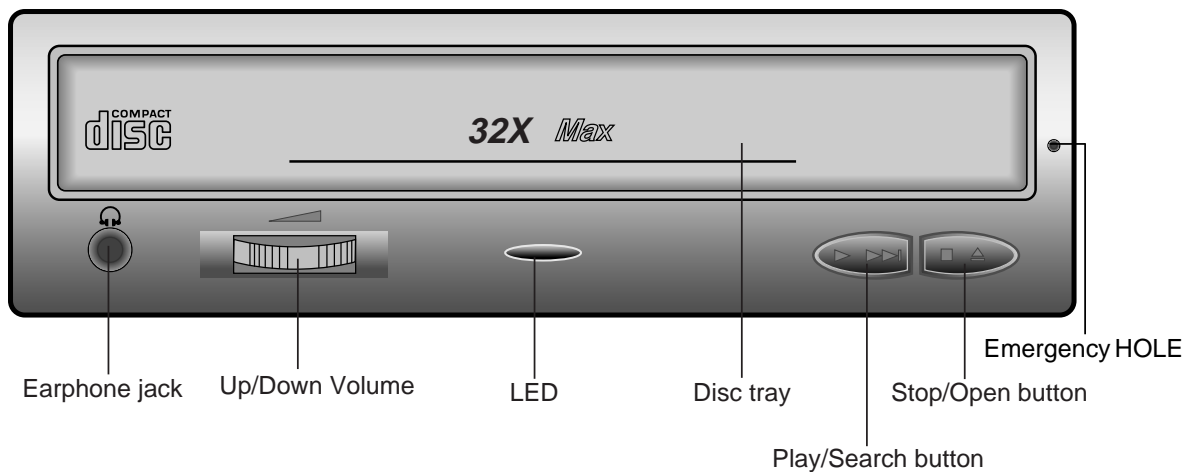

2.Rear

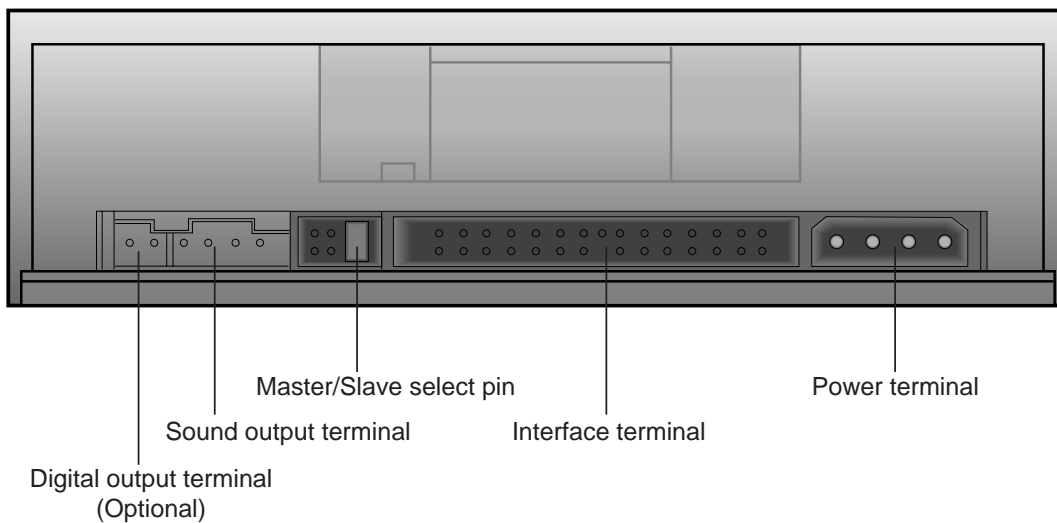

■ Disassembly Method

1. COVER BOTTOM ASSY disassembly

Remove 4 screws (23) on the bottom of COVER BOTTOM ASSY, lift the back up and disassemble COVER BOTTOM ASSY as Figure Page 4.

2. COVER-TOP disassembly

After disassembling 4 hooks of FRONT ASSY(2) from COVER TOP(1), pull COVER TOP(1) forward and disassemble it.

3. ASSY DECK+PCB MAIN disassembly

Disassemble FPC PICK-UP (24) and FPC MOTOR (25) connected between assy deck and PCB main, then disassemble between deck and PCB main.

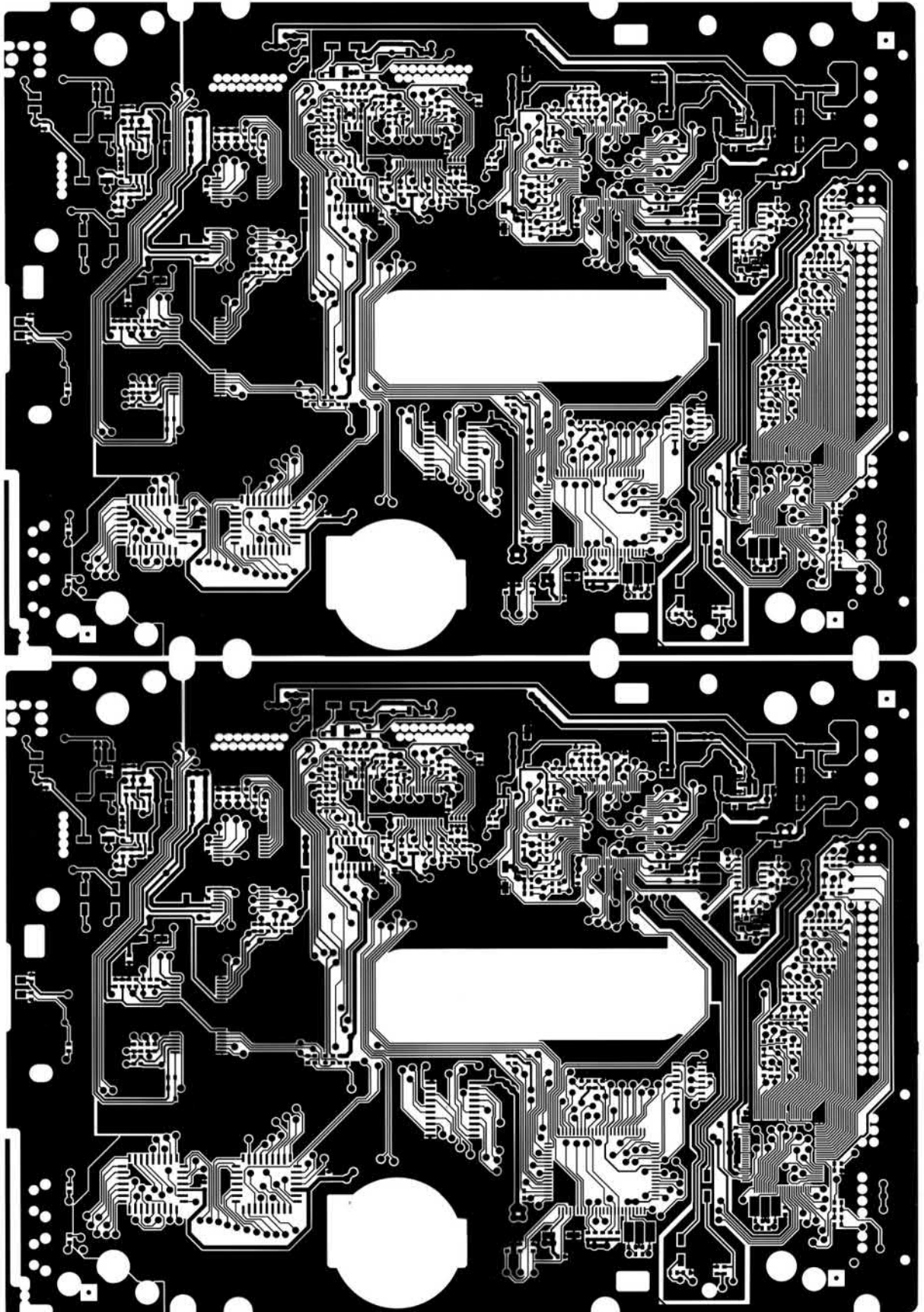

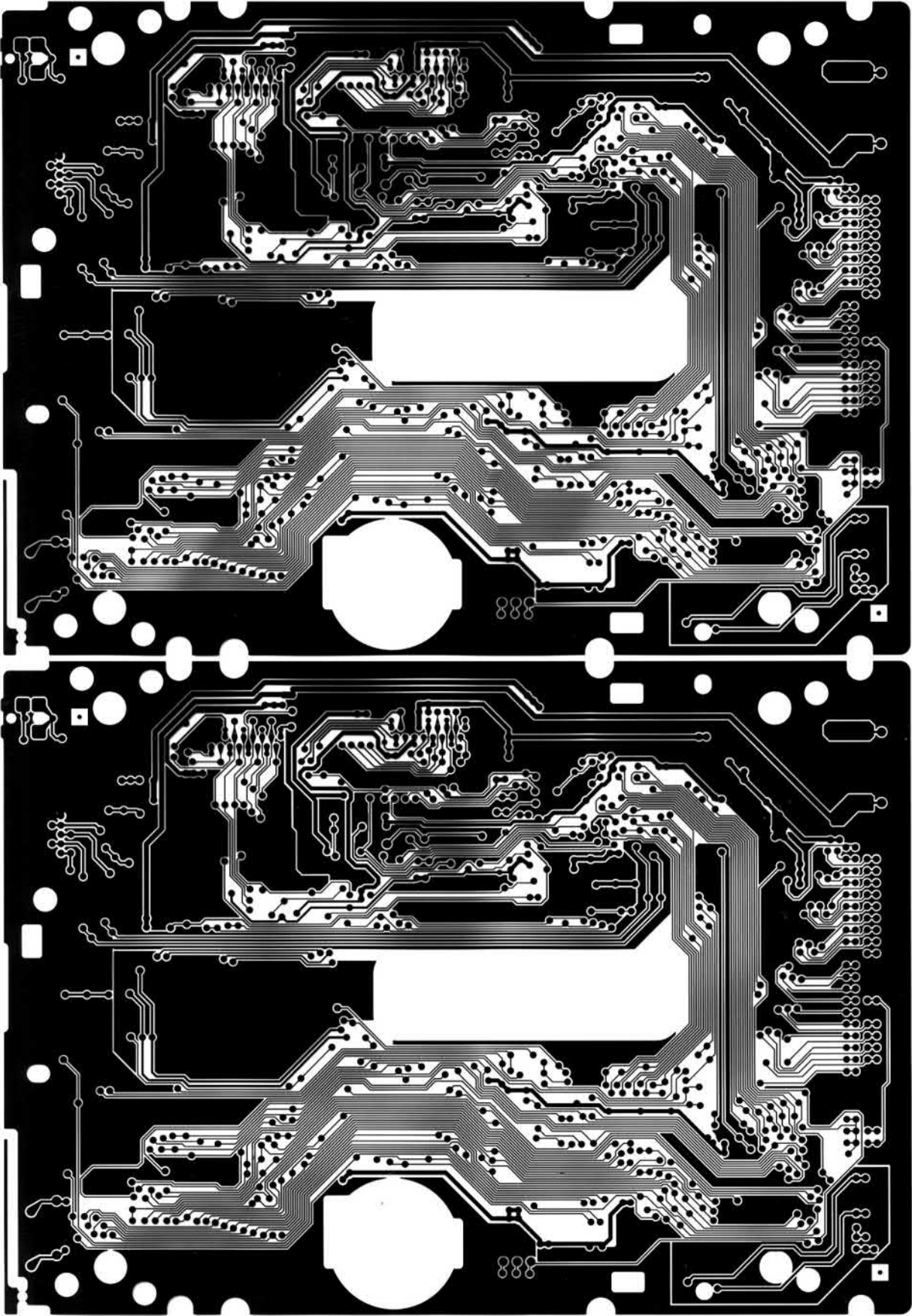

Troubleshooting

Equipments required at repair

1. Oscilloscope(100MHz and more)
2. PROBE for Oscilloscope(10:1)
3. PC(486 and more)

Verify the circuit of power unit and the first status(Plug-in the power cable without I/F cable and verify.)

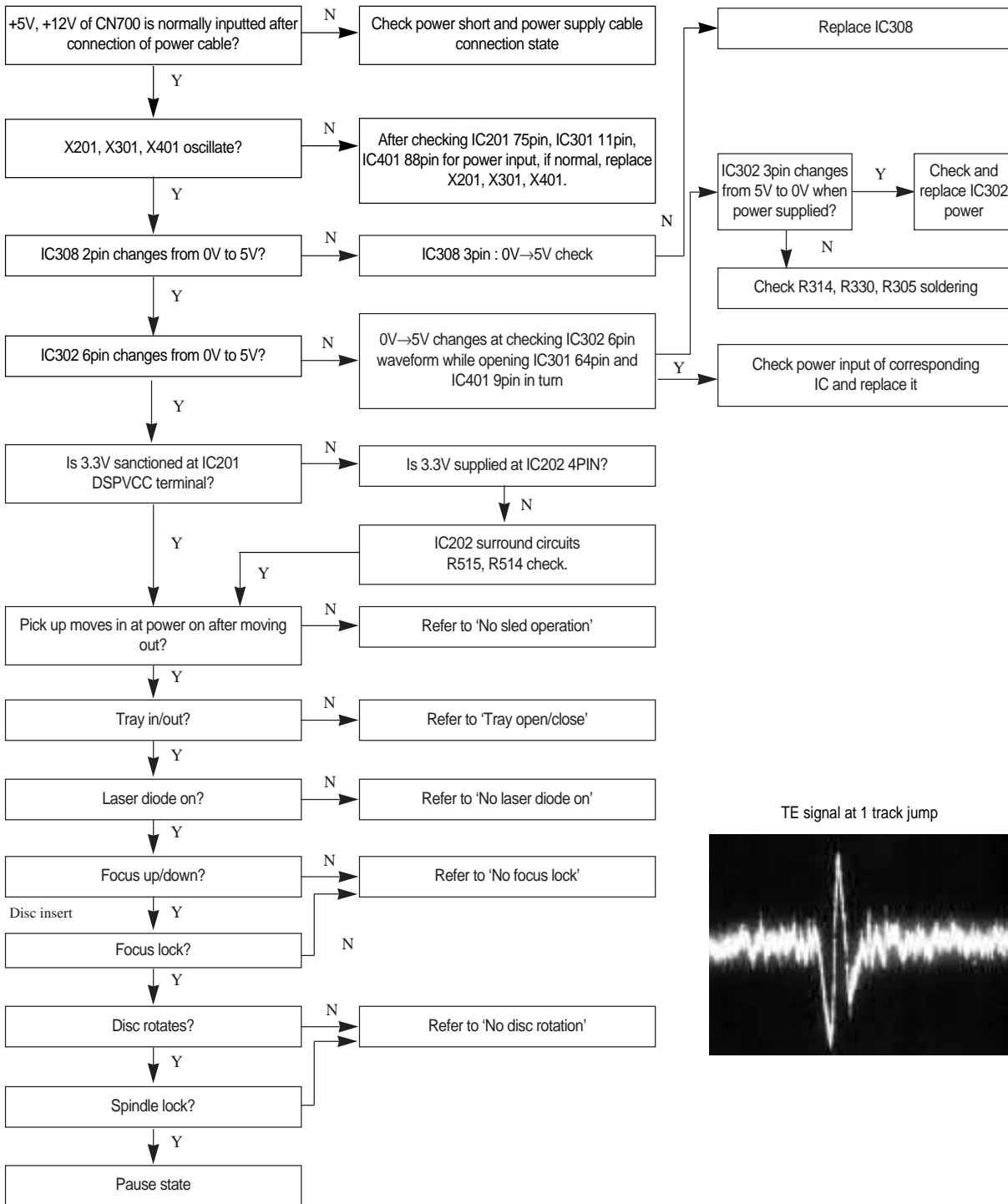

TE signal at 1 track jump



❖ Pause state : LED off as disc rotation state and continue 1 track jump

No tray open/close

❖ FPC : Flexible Printed Circuit

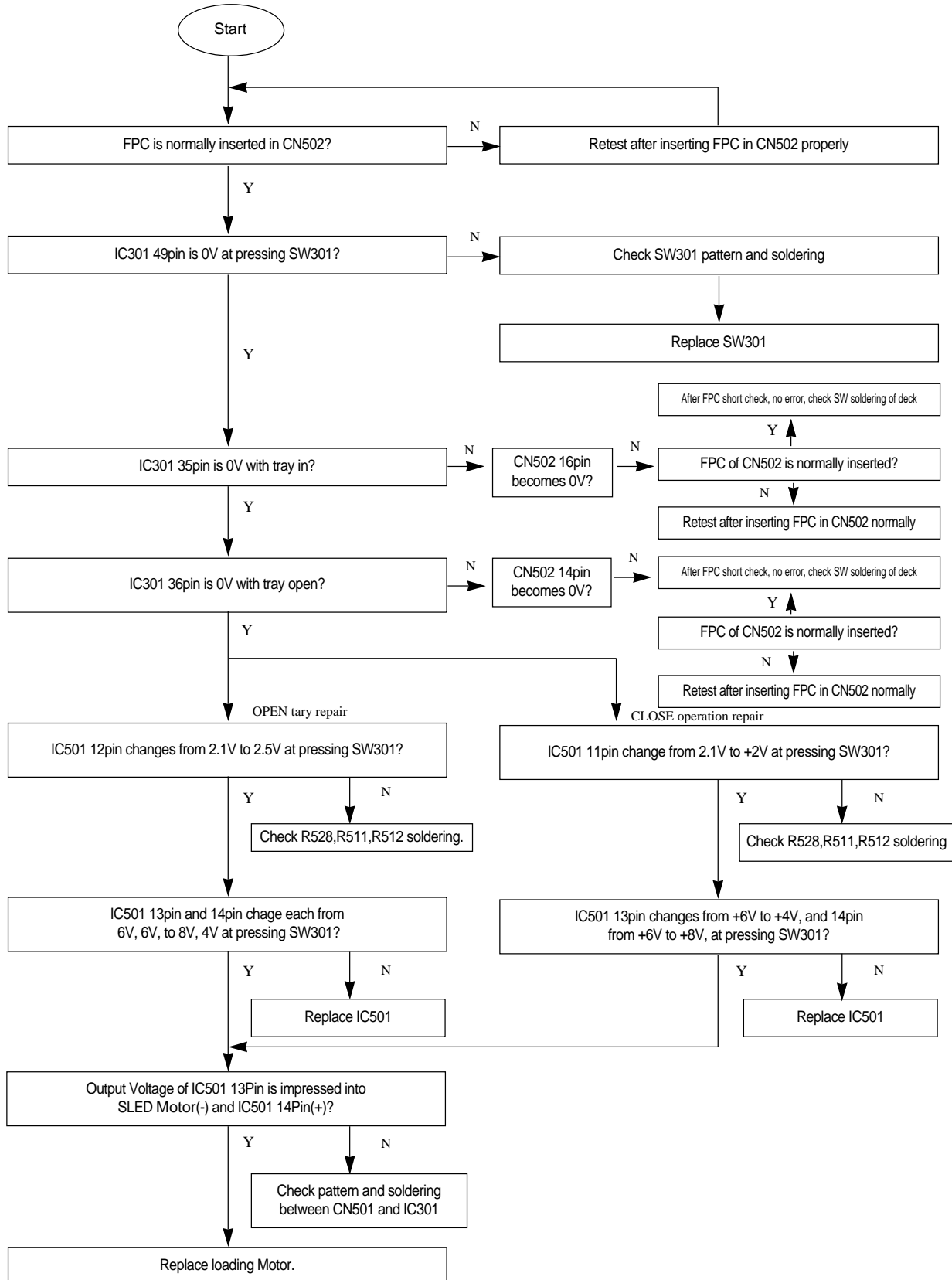

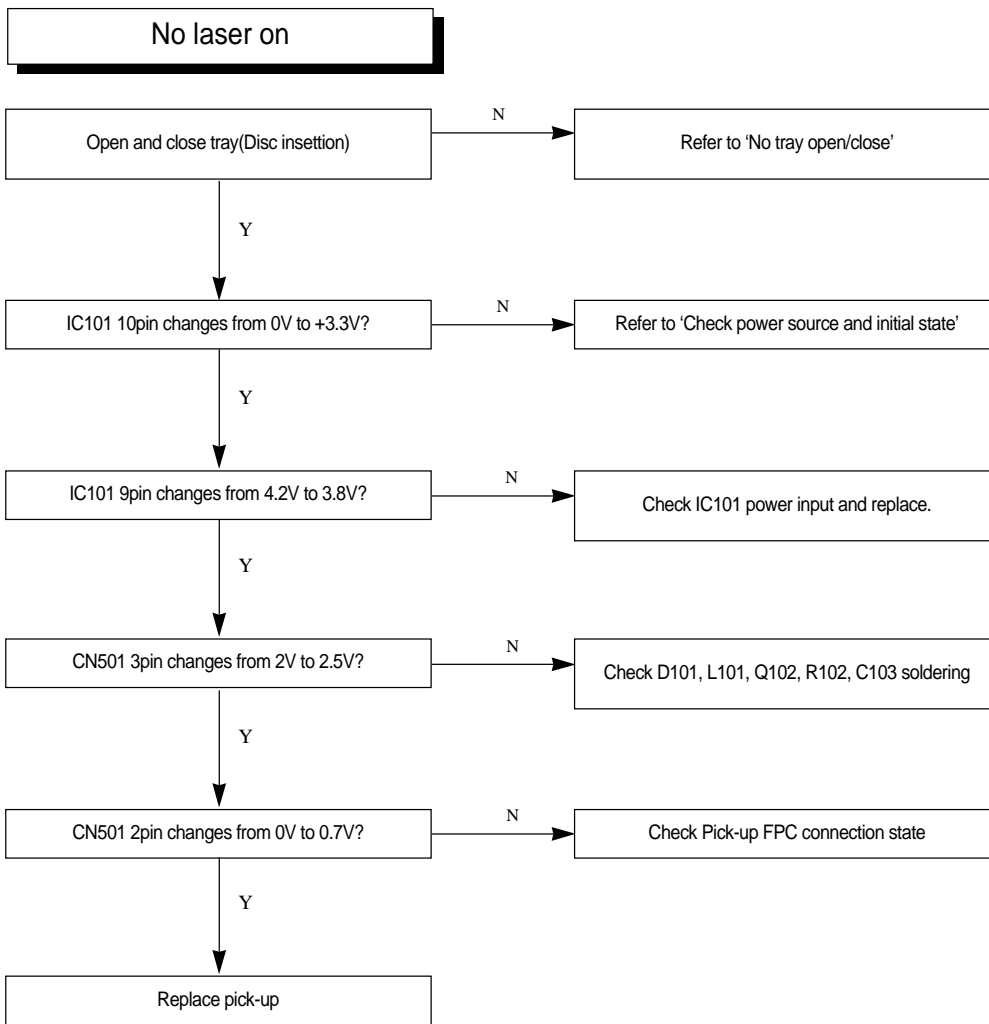

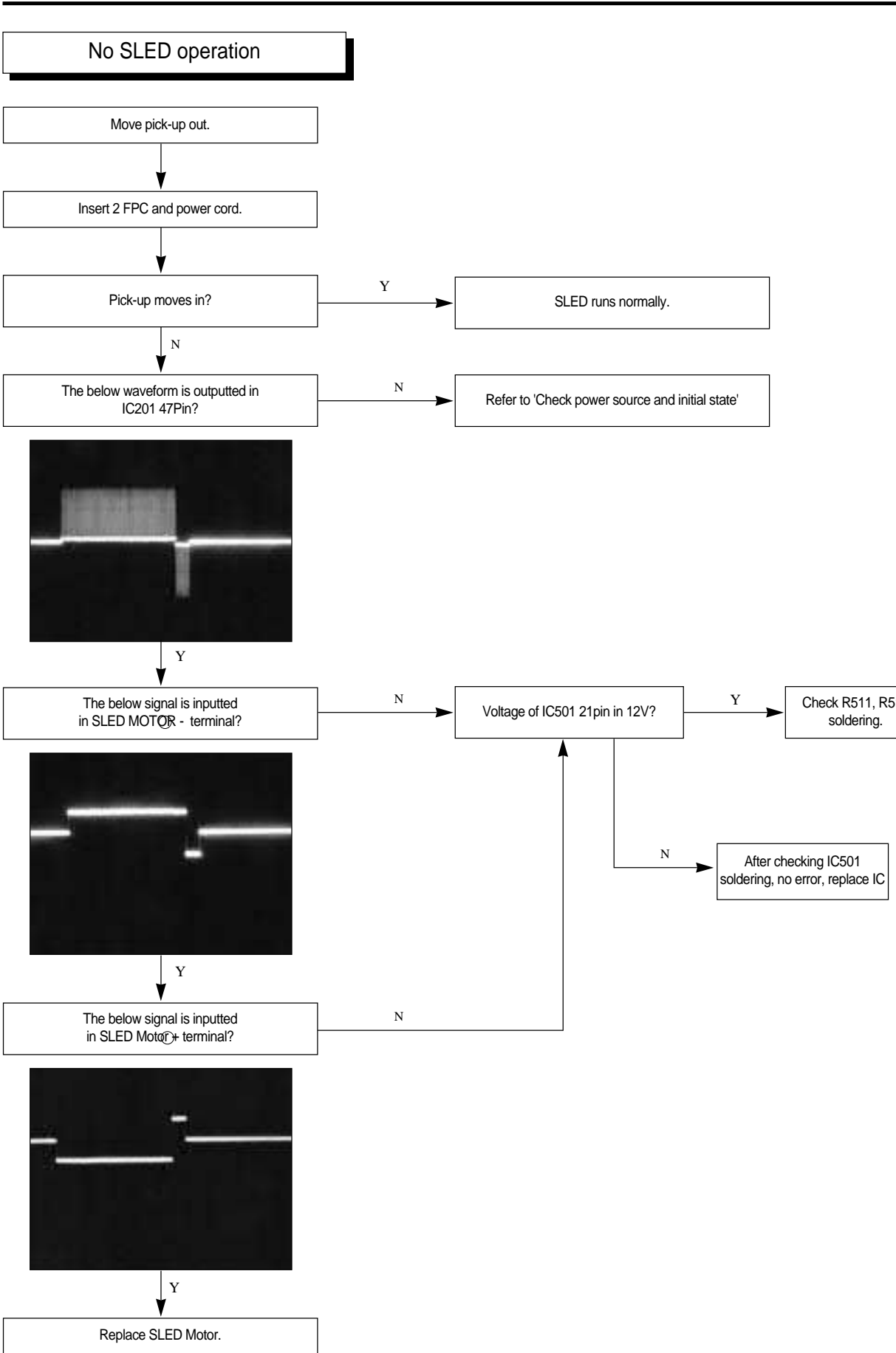

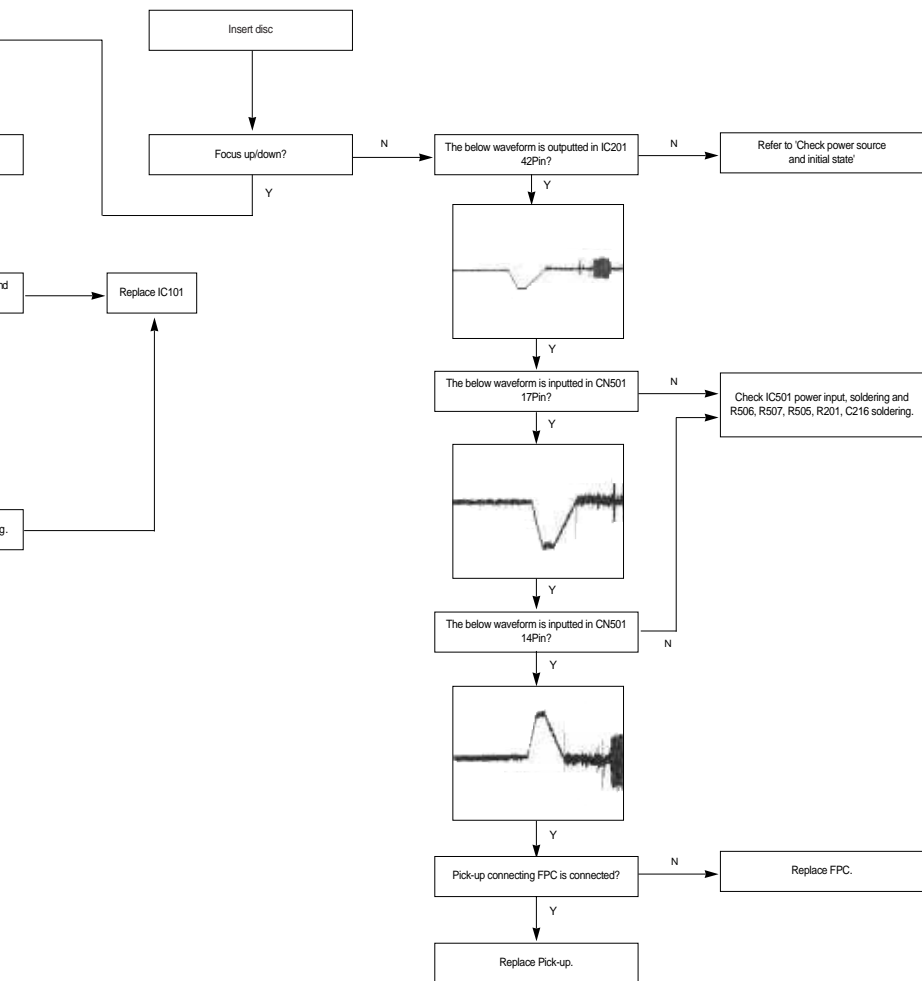

No spindle motor rotation

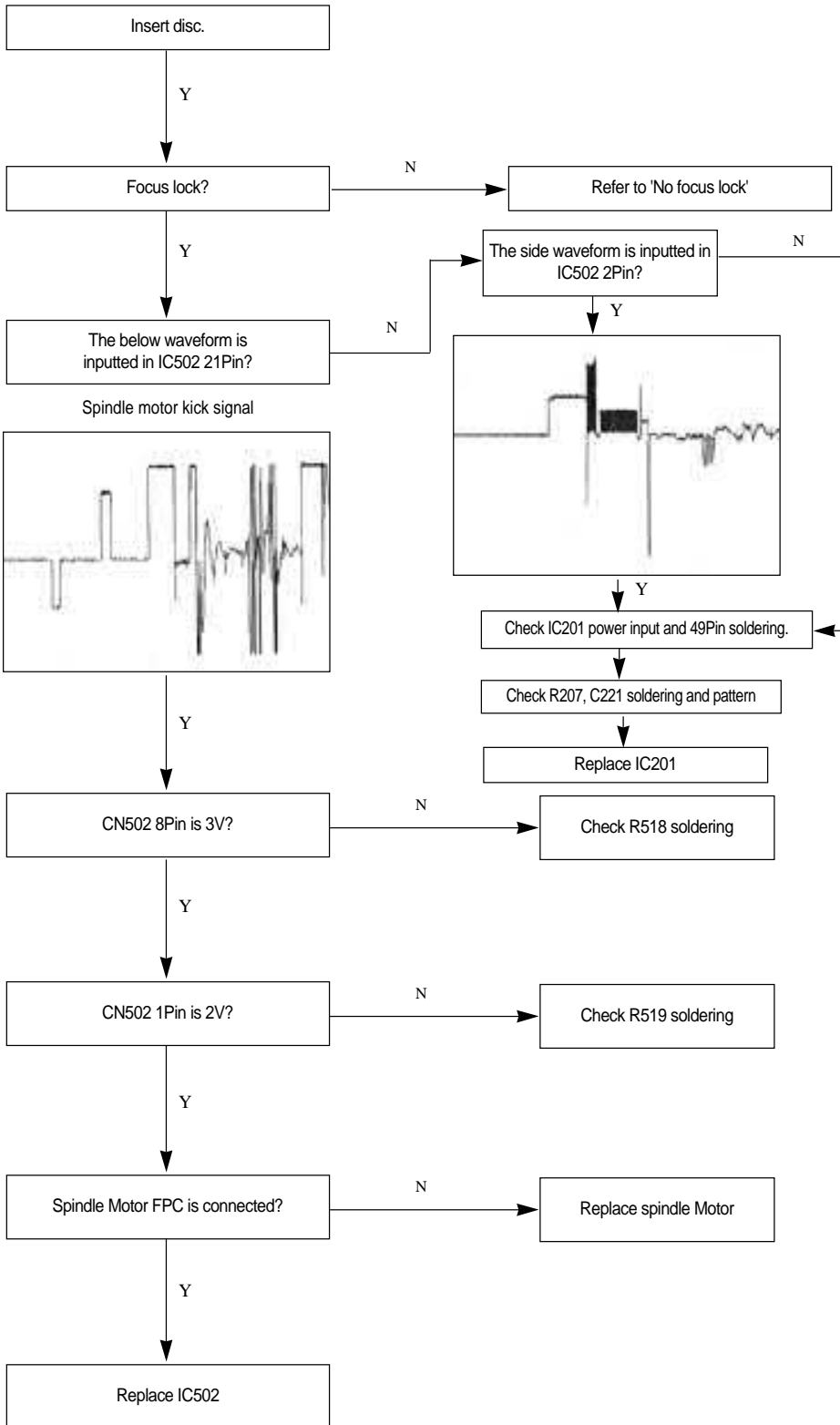

No audio output

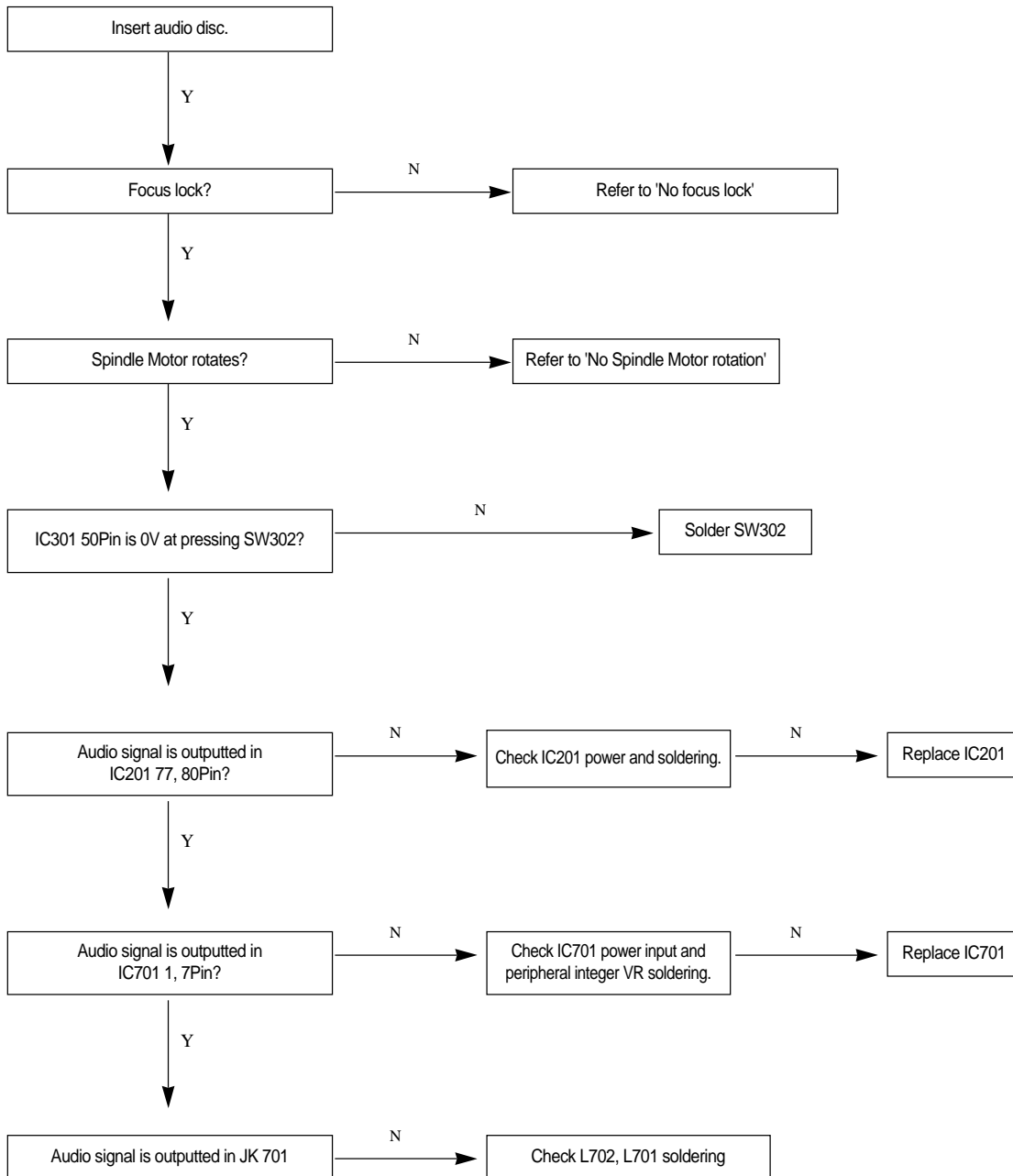

When installing is impossible

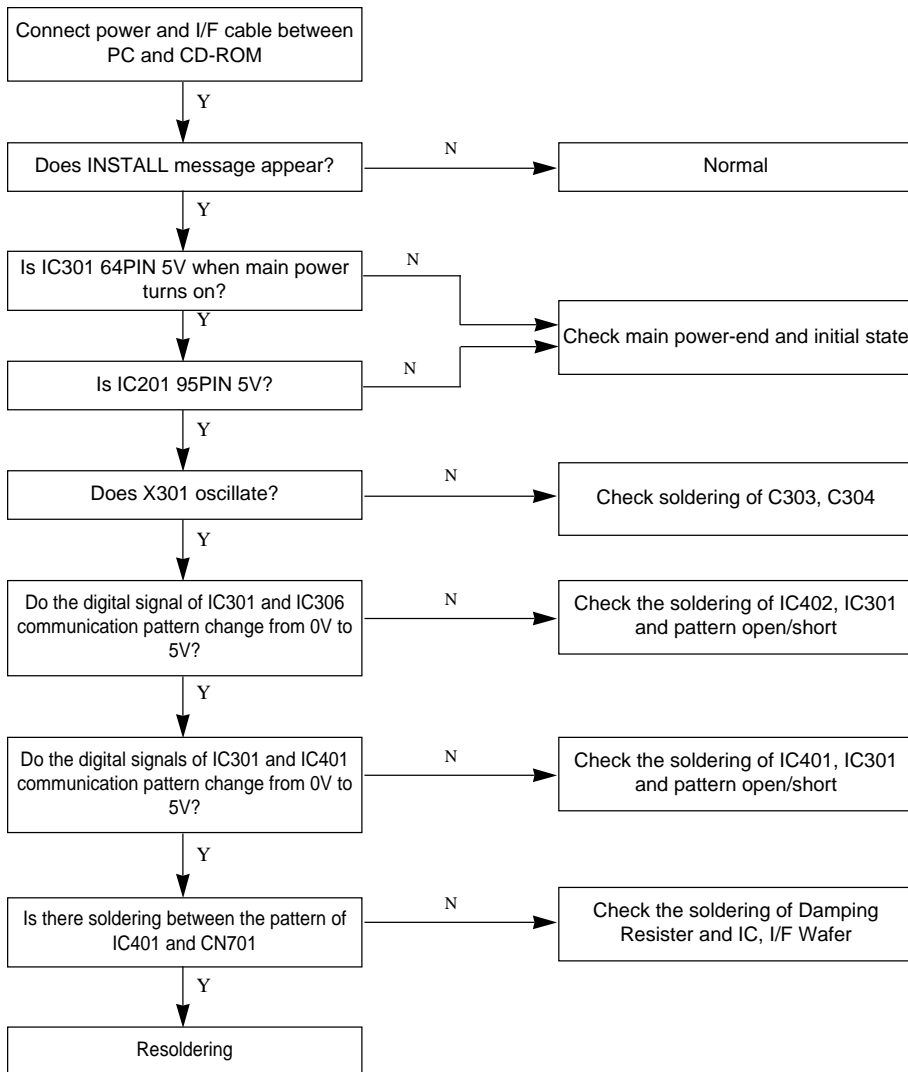

■ Packing Options

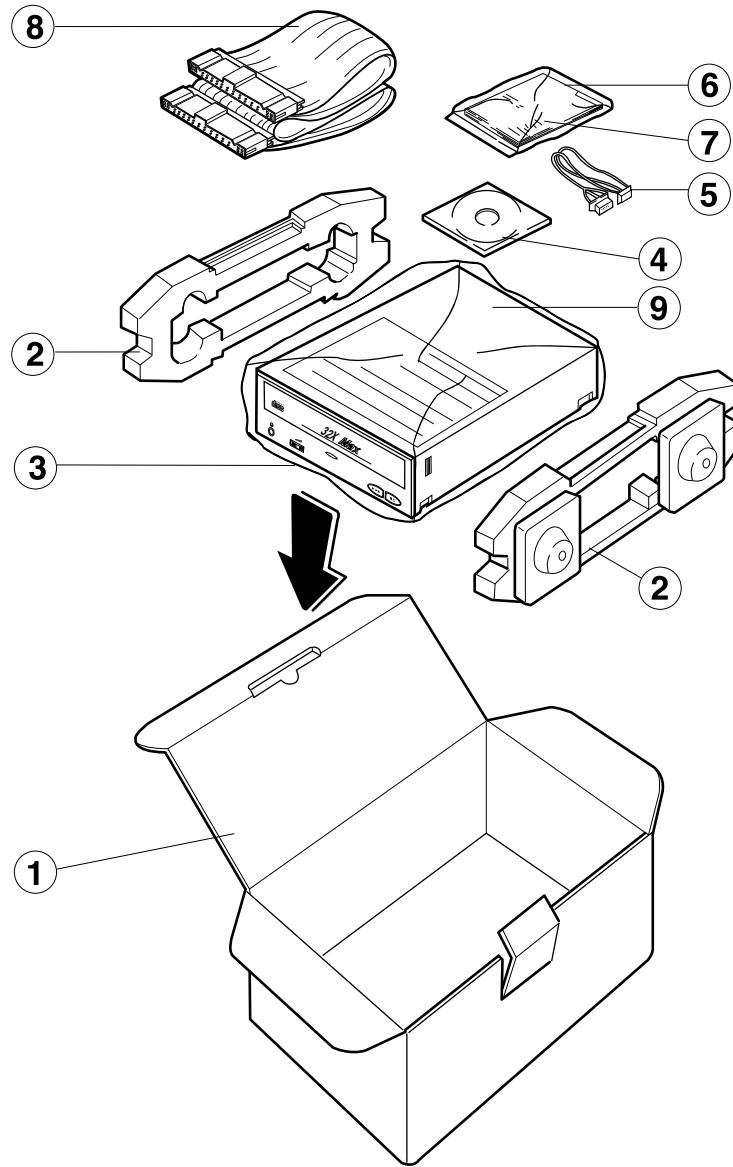

NO	CODE NO.	PARTS	SPECIFICATION	COUNT	REMARK
1	BG69-50015A	BOX SYSTEM	SW-E MANILA 400g	1	
2	BG69-20003A	CUSHION-SET	EPE WHITE	2	
3	BE69-30304A	PE-BAG	T0.1X270X260 ANTI	1	
4	BG46-30001J	INSTALL-DISK	SHARED W/ SCR-3230	1	
5	BG39-40010A	CBF-HARNESS	4P, 500mm	1	
6	BE69-30304A	PE-BAG	T0.1X270X260 ANTI	1	
7	BG68-10010A	MANUAL-USERS	CD-ROM(Korean)	1	
	BG68-10011A	MANUAL-USERS	CD-ROM(Eng/Ger)	1	
8	BG39-30002A	CABLE-IF	40 Pin I/F Cable	1	
9		SET	SCR-3232	1	

IC

NO	CODE NO	PARTS	SPEC	LOCATION NO	Q'TY
1	0903-000006	IC-MICRO CONTROLLER	KS88C4400	IC301	1
2	1102-001024	PROM	AT27C512R	IC306	1
3	1201-001231	RF-AMP	TA2119FN	IC101	1
4	BG14-10001H	IC SIGNAL PROCESSOR	TC9450F	IC201	1
5	0904-001237	IC-CONTROLLER	TC9466FA	IC401	1
6	1003-001068	IC MOTOR DRIVER	BA6849FP	IC502	1
7	1003-001130	IC 4-CH DRIVER	KA3012D	IC501	1
8	1203-001005	IC-VOLTAGE DETECTOR	XC61AC3502M	IC308	1
9	1203-001473	IC-VOLTAGE REGULATOR	PQ20WZ51	IC202	1
10	0801-002353	IC-CMOS LOGIC	74VHCT00	IC302	1
11	0803-000605	IC-TTL LOGIC	74LS374	IC305	1
12	1201-000003	IC-AMPLIFIER	3414A	IC701	1

R-CHIP-1

NO	CODE NO	PARTS	SPEC	LOCATION NO	Q'TY
1	2007-000070	R-CHIP	0 ohm	R108,109,124,208,275,307,314,327,501,817,C 206,L101	12
2	2007-000036	R-CHIP	2 ohm	R520,521,522,523	4
3	2007-000882	R-CHIP	4.7 ohm	R211	1
4	2007-001442	R-CHIP	10 ohm	R102	1
5	2007-000071	R-CHIP	22 ohm	R402,403,406,408,409,416,417,418,419, 420,421,422,423,424,425,426,427,428, 429,430,431	21
	2007-000115	R-CHIP	82 ohm	R404,405,407,410,411,412,413,414	8
6	2007-000074	R-CHIP	100 ohm	R309,310	2
7	2007-000116	R-CHIP	120 ohm	R308	1
8	2007-000075	R-CHIP	220 ohm	R101,103,518,519	4
9	2007-000763	R-CHIP	330 ohm	R135, 303	2
10	2007-000077	R-CHIP	470 ohm	R330	1
11	2007-000119	R-CHIP	560 ohm	R614	1
12	2007-000078	R-CHIP	1 Kohm	R117,119,123,201,202,326,703,705,706,708, 715,720	12
13	2007-000122	R-CHIP	1.2 Kohm	R436	1
14	2007-000080	R-CHIP	2 Kohm	R615	1
15	2007-000124	R-CHIP	2.2 Kohm	R532,533,733,734	4
16	2007-000662	R-CHIP	2.2 Kohm	NR100	1

R-CHIP-2

NO	CODE NO	PARTS	SPEC	LOCATION NO	Q'TY
17		R-CHIP	2.4 Kohm	R118	1
18	2007-000082	R-CHIP	3.3 Kohm	R203,204,207	3
19	2007-000084	R-CHIP	4.7 Kohm	R305,312,313,317,319,320,321,323,324,325	10
20	2007-000962	R-CHIP	5.1 Kohm	R528	1
21	2007-000090	R-CHIP	10 Kohm	R121,272,280,304,315,316,331,332,432,433, 438,439,440,442,443,717,718	17
22	2007-000091	R-CHIP	12 Kohm	R121,272	2
23	2007-000458	R-CHIP	18 Kohm	R276	1
24	2007-000094	R-CHIP	22 Kohm	R277,278,704,709	4
25	2007-000616	R-CHIP	24 Kohm	R271	1
26	2007-000655	R-CHIP	27 Kohm	R112,113	2
27	2007-000134	R-CHIP	33 Kohm	R110,111,273,274,529	5
28	2007-000939	R-CHIP	47 Kohm	R114,116,435,441	4
29	2007-000100	R-CHIP	68 Kohm	R506,507,515,517,701,714	6
30	2007-000131	R-CHIP	91 Kohm	R702,707	2
31	2007-000102	R-CHIP	100 Kohm	R333	1
32	2007-000060	R-CHIP	100 Kohm-F	R505,508,509,510,512,514,516	8
33	2007-000106	R-CHIP	220 Kohm	R530,531	2
34	2007-000107	R-CHIP	470 Kohm	R334	1
35	2007-000065	R-CHIP	2.2 Kohm	R210	1

C-CHIP

NO	CODE NO	PARTS	SPEC	LOCATION NO	Q'TY
1		C-CERAMIC	3 pf	C124	1
2	2203-001567	C-CERAMIC	10 pf	C207,208	2
3	2203-001103	C-CERAMIC	6.8 nf	C509	1
4	2203-000477	C-CERAMIC	1 nf	C312	1
5	2203-000715	C-CERAMIC	3.3 nf	C216,219	2
6	2203-000888	C-CERAMIC	4.7 nf	C209	1
7	2203-000257	C-CERAMIC	10 nf	C111,202,211,274,521,609	6
8	2203-000372	C-CERAMIC	15 nf	C273	1
9	2203-001634	C-CERAMIC	33 nf	C203,215	2
10	2203-000062	C-CERAMIC	47 nf	C217,218	2
11	2203-001556	C-CERAMIC	100 nf	C100,104,113,213,221,222,275,301,306,311,307 308,313,403,404,405,406,407,515,507,508,513 514,515,516,517,519,520,601,602,603,608 702,703,704,705	36

C-CHIP (continued)

NO	CODE NO	PARTS	SPEC	LOCATION NO	Q'TY
12	2203-001402	C-CERAMIC	220 nf	C112	1
13	2203-000919	C-CERAMIC	470 nf	C510,511,512	3
14	2203-001083	C-CERAMIC	5 pf	C303,304	2
15	2203-001618	C-CERAMIC	27 pf	C401,402	2
16	2203-001636	C-CERAMIC	33 pf	C110	1
17	2203-001697	C-CERAMIC	82 pf	C701,706	2
18	2203-001656	C-CERAMIC	470 pf	C262	1
19	2203-000477	C-CERAMIC	1 uf	C106,114,115,116	4
20	2402-001009	C-CERAMIC	100uf/6.3V	C276,607,610,713,714	5
21	2402-000112	C-CERAMIC	10uf/16V	C709,710,712,715	4
22	2402-000136	C-CERAMIC	22uf/16V	C278,518	2
23	2402-000008	C-CERAMIC	47uf/16V	C103,105,107,109,212,214,302,604,711	9

OTHER

NO	CODE NO	PARTS	SPEC	LOCATION NO	Q'TY
1	3708-001107	CONNECTOR-FPC	CNN-16PIN	CN502	1
2	3708-001254	CONNECTOR-FPC	CNN-17PIN	CN501	1
3	3711-003262	CONNECTOR-HEADER:56P	CN701	CN701	1
4	3710-000001	CONNECTOR-SOCKET:2P	1R,2.54mm		1
5	3301-001082	CORE-FERRITE BEAD	CIB32P600NEM	B601,602,L701,702	4
6	0407-000116	DIODE-ARRAY	DAP202K	D101	1
7	3722-000107	EARPHONE JACK	HSJ1A15	JK701	1
8	0601-000005	LED-CHIP	SML-010MTT86	D301	1
9	BG99-90001B	PCB MAIN			1
10	2802-001068	RESONATOR	20MHz	X301	1
11	2802-001047	RESONATOR	33.86MHz	X201	1
12	2802-001047	RESONATOR	25.4MHz	X401	1
13	3704-000249	SOCKET-IC:32P	PLCC, 1.27mm		1
14	3404-001030	SWITCH-TACT	JPT1236HA	SW301,302	2
15	0501-000338	TR-SMALL		Q101	1
16	0501-000251	TR-SMALL	BC807:PNP	Q102	1
17	2101-001004	VR-ROTARY	20K-VR	VR701	1
18	2802-001047	THERMISTER	NTH5G1M42B104	T301	1

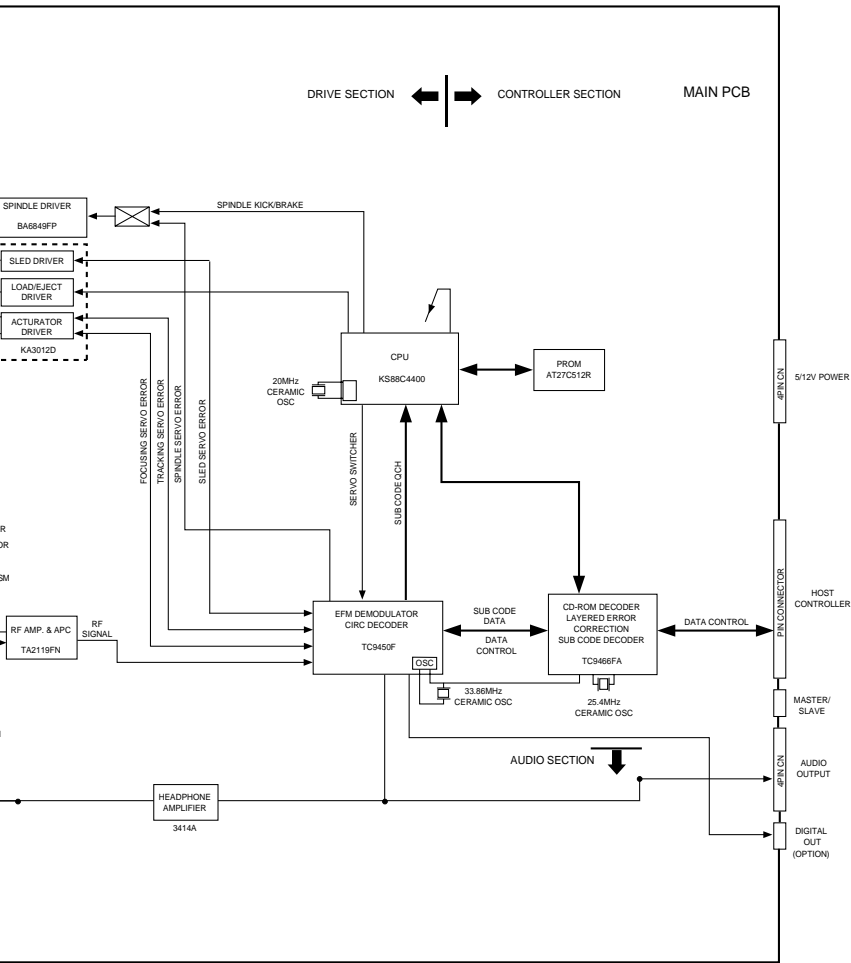

■ Main Components Block Diagram and Pin Descriptions

• KS88C4400 MICROCONTROLLER

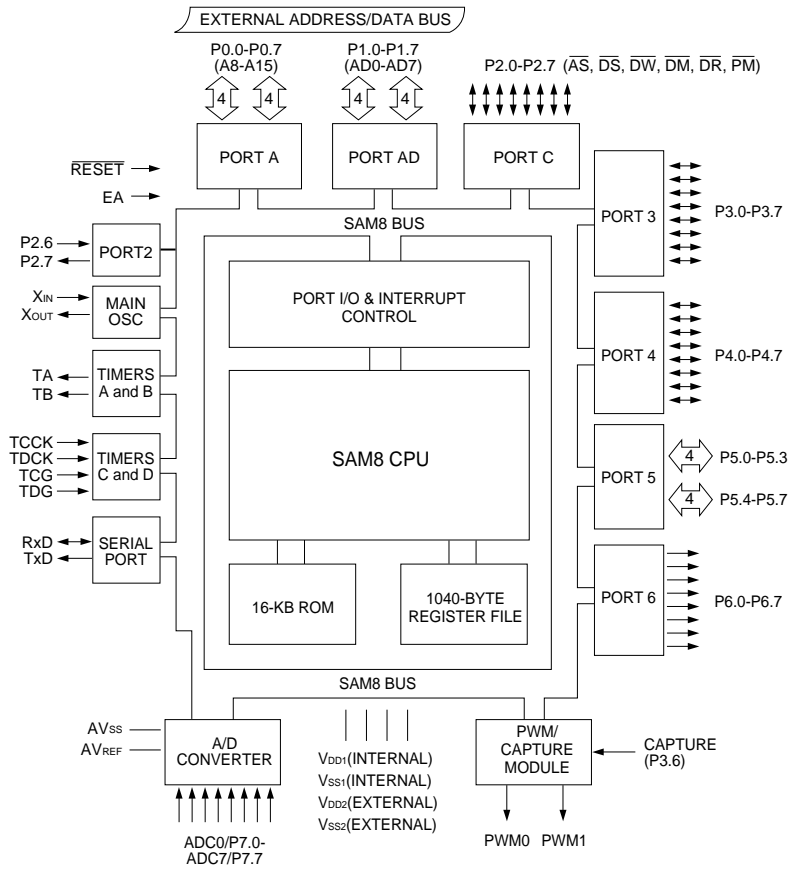
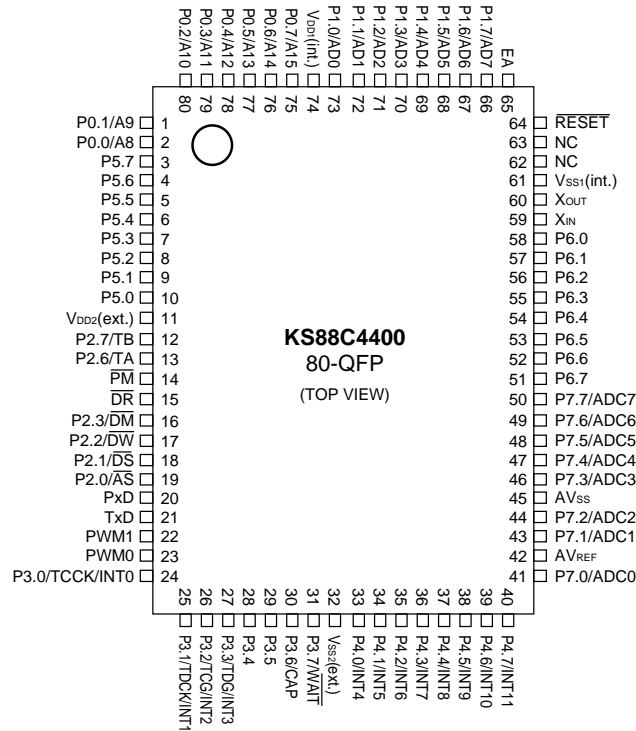

MICOM PIN DESCRIPTIONS

PIN	NAME	FUNCTION	PIN	NAME	FUNCTION
1	A9	ADDRESS LINE	41	TEST_P1	PRODUCTION TEST PIN 0
2	A8	ADDRESS LINE	42	AVref	CVCC
3	/XCE	MICOM INTERFACE CHIP ENABLE	43	TEST_P2	PRODUCTION TEST PIN 1
4	/XCM	MICOM INTERFACE FIRST WORD ENABLE	44	TEST_P3	PRODUCTION TEST PIN2
5	/XRD	MICOM INTERFACE READ SIGNAL	45	Avss	GROUND
6	/XWR	MICOM INTERFACE WRITE SIGNAL	46	NC	NO CONNECTION
7	BUS3	MICOM INTERFACE DATA INPUT/OUTPUT SIGNAL	47	FVO	NOT USE
8	BUS2	MICOM INTERFACE DATA INPUT/OUTPUT SIGNAL	48	UBL	UNBALLACE DISC CHECK
9	BUS1	MICOM INTERFACE DATA INPUT/OUTPUT SIGNAL	49	/EJECT	EJECT KEY INPUT
10	BUS0	MICOM INTERFACE DATA INPUT/OUTPUT SIGNAL	50	/PLAY	PLAY KEY INPUT
11	VDD2	VCC	51	NC	NO CONNECTION
12	NC	NO CONNECTION	52	NC	NO CONNECTION
13	NC	NO CONNECTION CVCC	53	NC	NO CONNECTION
14	/CE	FLASH CHIP ENABLE	54	NC	NO CONNECTION
15	/URO	TC 9466 IC READ	55	XRST	DSP RESET
16	/UCS	TC 9466 IC CHIP SELECT	56	LED_BUSY	BUSY LED
17	/UWR	TC 9466 IC WRITE	57	EMPHA	EMPHASIS CONTROL
18	NC	NO CONNECTION	58	NC	NO CONNECTION
19	CLK	TC 9466 IC INTERRUPT	59	XIN	RESONATOR CLOCK IN
20	NC	NO CONNECTION	60	XOUT	RESONATOR CLOCK OUT
21	NC	NO CONNECTION	61	Vss1	GROUND
22	NC	NO CONNECTION	62	NC	NO CONNECTION
23	NC	NO CONNECTION	63	NC	NO CONNECTION
24	FLAGA	TRACK ZERO CROSS CHECK	64	RESET	MICOM RESET
25	FLAGC	FOCUS OK CHECK	65	VCC	VCC
26	GFS	NOT USE	66	A7	ADDRESS LINE AND DATA PORT
27	SPM_DIR	SPINDLE KICK/BRAKE	67	A6	ADDRESS LINE AND DATA PORT
28	NC	NO CONNECTION	68	A5	ADDRESS LINE AND DATA PORT
29	DRV_MUTE	KA3012 MUTE	69	A4	ADDRESS LINE AND DATA PORT
30	FG	SPINDLE FG INPUT	70	A3	ADDRESS LINE AND DATA PORT
31	SPM_DIR	SPM-DIR	71	A2	ADDRESS LINE AND DATA PORT
32	VSS	GROUND	72	A1	ADDRESS LINE AND DATA PORT
33	NC	NO CONNECTION	73	A0	ADDRESS LINE AND DATA PORT
34	D_INT	ROM DECODER INTERRUPT	74	VDD	VCC
35	CLOSE	TRAY CLOSE SIGNAL	75	A15	ADDRESS LINE
36	OPEN	TRAY OPEN SIGNAL	76	A14	ADDRESS LINE
37	NC	NO CONNECTION	77	A13	ADDRESS LINE
38	MON	SPINDLE MOTOR ON/OFF	78	A12	ADDRESS LINE
39	NC	NO CONNECTION	79	A11	ADDRESS LINE
40	SCOR	SUB CODE SYNC INTERRUPT	80	A10	ADDRESS LINE

• TC9466F QFP PIN DIAGRAM

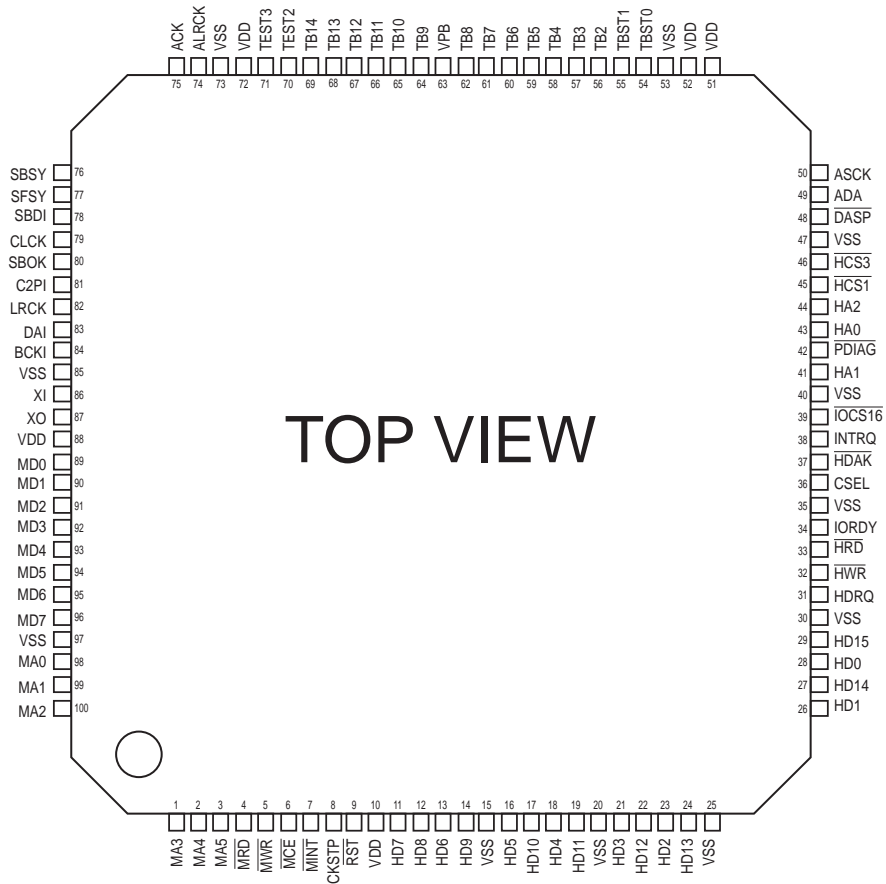

• TC9466F FUNCTIONAL BLOCK DIAGRAM

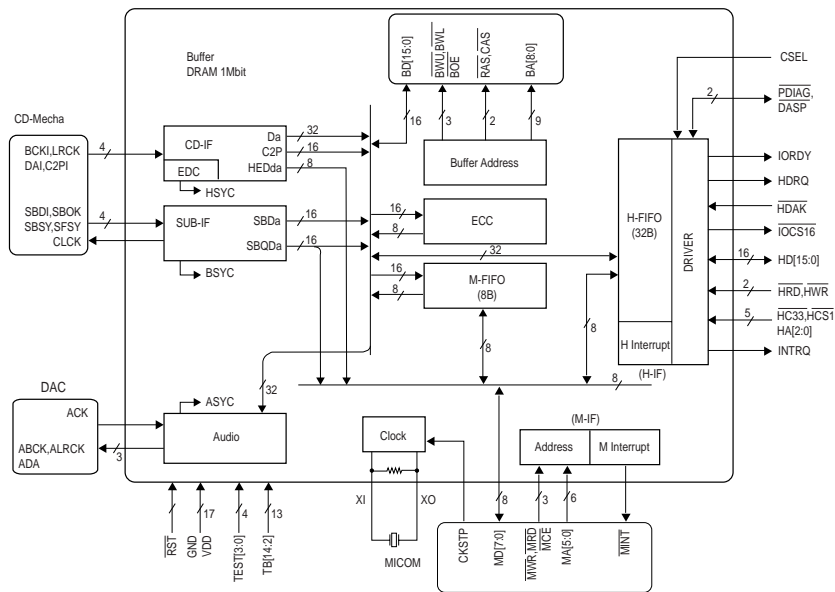

PIN DESCRIPTIONS

NO	SYMBOL	DESCRIPTIONS	NO	SYMBOL	DESCRIPTIONS
1	MA3	MICOM ADDRESS INPUT	51	VDD	POWER SOURCE TERMINAL
2	MA4	MICOM ADDRESS INPUT	52	VDD	POWER SOURCE TERMINAL
3	MA5	MICOM ADDRESS INPUT	53	VSS	GROUND TERMINAL
4	MRD	MICOM READ SIGNAL INPUT	54	TEST0	TEST TERMINAL
5	MWR	MICOM WRITE SIGNAL INPUT	55	TEST1	TEST TERMINAL
6	MCE	CHIP ENABLE SIGNAL INPUT	56	TB2	TEST TERMINAL
7	KINT	INTERRUPT REQUEST OUTPUT	57	TB3	TEST TERMINAL
8	CKSTP	CLOCK PARTIAL STOP INPUT	58	TB4	TEST TERMINAL
9	RST	RESET TERMINAL	59	TB5	TEST TERMINAL
10	VDD	POWER SOURCE TERMINAL	60	TB6	TEST TERMINAL
11	HD7	HOST DATA INPUT	61	TB7	TEST TERMINAL
12	HD8	HOST DATA INPUT	62	TB8	TEST TERMINAL
13	HD6	HOST DATA INPUT	63	VPB	GROUND TERMINAL (DRAM AREA)
14	HD9	HOST DATA INPUT	64	TB9	TEST TERMINAL
15	VSS	GROUND TERMINAL	65	TB10	TEST TERMINAL
16	HD5	HOST DATA INPUT	66	TB11	TEST TERMINAL
17	HD10	HOST DATA INPUT	67	TB12	TEST TERMINAL
18	HD4	HOST DATA INPUT	68	TB13	TEST TERMINAL
19	HD11	HOST DATA INPUT	69	TB14	TEST TERMINAL
20	VSS	GROUND TERMINAL	70	TEST2	TEST TERMINAL
21	HD3	HOST DATA INPUT	71	TEST3	TEST TERMINAL
22	HD12	HOST DATA INPUT	72	VDD	POWER SOURCE TERMINAL
23	HD2	HOST DATA INPUT	73	VSS	GROUND TERMINAL
24	HD13	HOST DATA INPUT	74	ALRCK	LRCK OUTPUT FOR DAC ON FAST PLAY
25	VSS	GROUND TERMINAL	75	ACK	BASE CLOCK INPUT ON FAST PLAY
26	HD1	HOST DATA INPUT	76	SBSY	SUBCODE BLOCK SYNC OUTPUT
27	HD14	HOST DATA INPUT	77	SFSY	SUBCODE DATA SYNC FRAME INPUT
28	HD0	HOST DATA INPUT	78	SBDI	SUBCODE DATA INPUT
29	HD15	HOST DATA INPUT	79	CLCK	SUBCODE DATA CLOCK OUTPUT
30	VSS	GROUND TERMINAL	80	SBOK	SUBCODE Q DATA FLAG INPUT
31	HDRQ	DATA REQUEST TERMINAL	81	C2PI	DATA CORRECTION FLAG INPUT
32	HWR	HOST WRITE SIGNAL INPUT	82	LRCK	CHANNEL CLOCK INPUT
33	HRD	HOST READ SIGNAL INPUT	83	DAI	DATA SIGNAL INPUT
34	IORDY	IO TRANSFER READY OUTPUT	84	BCKI	BIT CLOCK INPUT
35	VSS	GROUND TERMINAL	85	VSS	GROUND TERMINAL
36	CSEL	CABLE SELECT INPUT	86	XI	MASTER CLOCK I/O
37	HDAK	DATA ACKNOWLEDGE INPUT	87	XO	MASTER CLOCK I/O
38	INTRQ	INTERRUPT SIGNAL OUTPUT	88	VDD	POWER SOURCE TERMINAL
39	IOCS16	DATA BIT WIDE SELECT OUTPUT	89	MD0	MICOM DATA I/O
40	VSS	GROUND TERMINAL	90	MD1	MICOM DATA I/O
41	HA1	HOST ADDRESS 1 INPUT	91	MD2	MICOM DATA I/O
42	PDIAG	POST DIAGNOSTIC I/O	92	MD3	MICOM DATA I/O
43	HA0	HOST ADDRESS 0 INPUT	93	MD4	MICOM DATA I/O
44	HA2	HOST ADDRESS 2 INPUT	94	MD5	MICOM DATA I/O
45	HCS1	CHIP SELECT 1 INPUT	95	MD6	MICOM DATA I/O
46	HCS3	CHIP SELECT 3 INPUT	96	MD7	MICOM DATA I/O
47	VSS	GROUND TERMINAL	97	VSS	GROUND TERMINAL
48	DASP	DRIVE ACTIVE OUTPUT	98	MA0	MICOM ADDRESS INPUT
49	ADA	DATA OUTPUT FOR DAC ON FAST PLAY	99	MA1	MICOM ADDRESS INPUT
50	ABCK	BCK OUTPUT FOR DAC ON FAST PLAY	100	MA2	MICOM ADDRESS INPUT

• TC9450F (DSP CHIP)

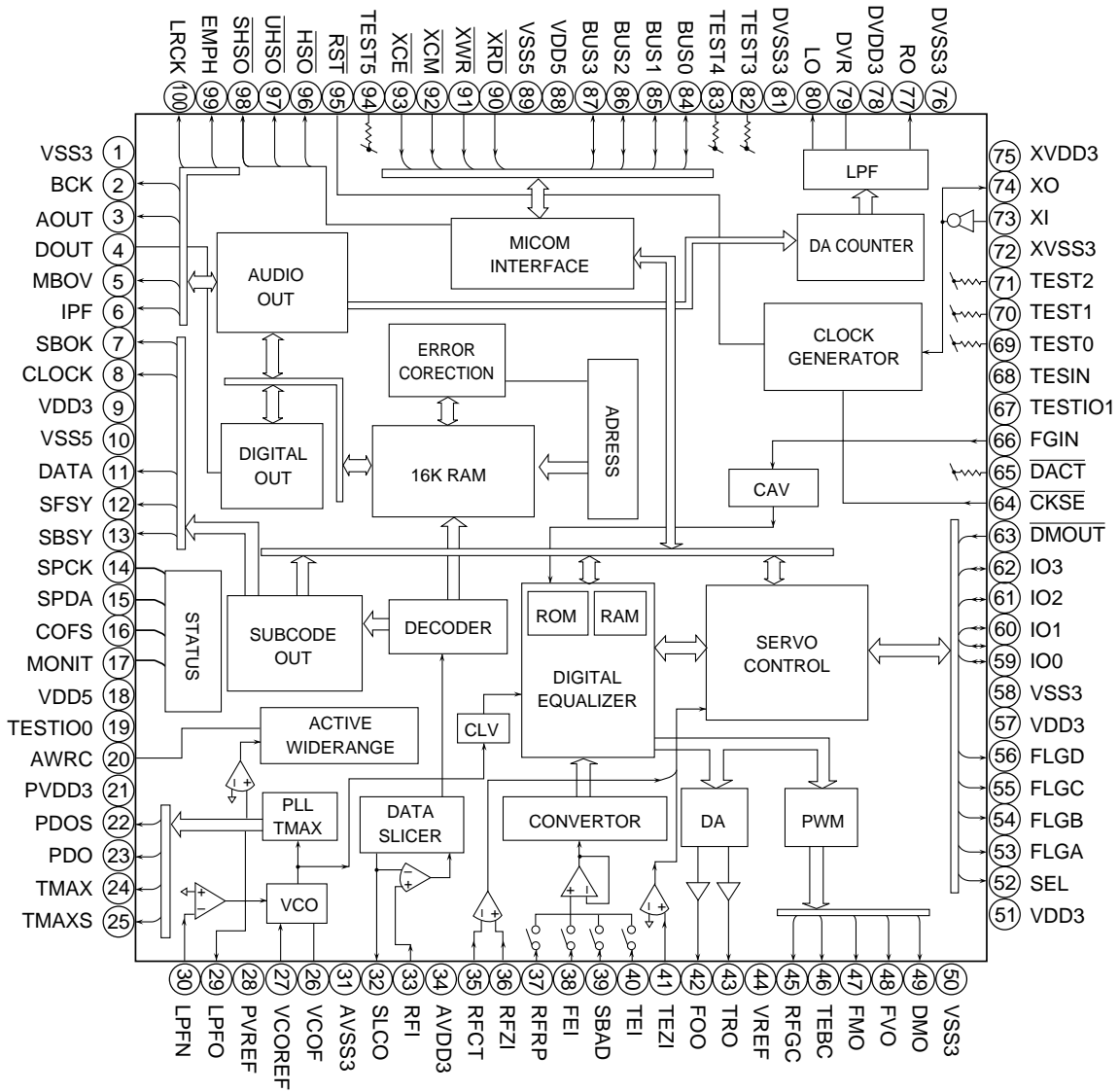

PIN DESCRIPTIONS

PIN NO	PIN NAME	DESCRIPTIONS	PIN NO	PIN NAME	DESCRIPTIONS
1	VSS3	DIGITAL GND TERMINAL	51	VDD3	DIGITAL +3.3V POWER SOURCE TERMINAL
2	BCK	BIT CLOCK OUTPUT TERMINAL (1.411MHz)	52	SEL	AUTO POWER CONTROL ON/OFF SIGNAL OUTPUT TERMINAL
3	AOUT	AUDIO DATA OUTPUT TERMINAL	53	FLGA	INTERNAL SIGNAL CHECKING FLAG TERMINAL
4	DOUT	DIGITAL DATA OUTPUT TERMINAL	54	FLGB	INTERNAL SIGNAL CHECKING FLAG TERMINAL
5	MBOV	BUFFER MEMORY OVER SIGNAL OUTPUT TERMINAL	55	FLGC	INTERNAL SIGNAL CHECKING FLAG TERMINAL
6	IPF	COMPLEMENTARY BLOCK OUTPUT TERMINAL	56	FLGD	INTERNAL SIGNAL CHECKING FLAG TERMINAL
7	SBOK	CRCC RESULT OUTPUT TERMINAL FOR SUBCODE Q DATA	57	VDD3	DIGITAL +3.3V POWER TERMINAL
8	CLCK	SUBCODE P-W DATA READ CLOCK TERMINAL	58	VSS3	DIGITAL GND
9	VDD3	DIGITAL +3.3V POWER TERMINAL	59	I00	GENERAL I/O TERMINAL
10	VSS5	DIGITAL GND TERMINAL	60	I01	GENERAL I/O TERMINAL
11	DATA	SUBCODE P-W OUTPUT TERMINAL	61	I02	GENERAL I/O TERMINAL
12	SFSY	PLAY DEVICE FRAME SYNC SIGNAL OUTPUT TERMINAL	62	I03	GENERAL I/O TERMINAL
13	SBSY	SUBCODE BLOCKING OUTPUT TERMINAL	63	/DMOUT	100-1 OUTPUT MODE SELECT TERMINAL
14	SPCK	DSP INTERNAL STATUS CHECKING CLOCK TERMINAL	64	/CKSE	OSCILLATING DEVICE SELECT TERMINAL
15	SPDA	DSP STATUS OUTPUT TERMINAL	65	/DACT	DIGITAL/ANALOG CONVERT TEST TERMINAL
16	COFS	ERROR CORRECTION CLOCK (7.35 MHz) OUTPUT TERMINAL	66	FGIN	DIGITAL/ANALOG CONVERT TEST TERMINAL
17	MONIT	DSP INTERNAL STATUS OUTPUT TERMINAL	67	TESI01	TEST INPUT TERMINAL
18	VDD5	DIGITAL +5V TERMINAL	68	TESIN	TEST INPUT TERMINAL
19	TEST00	TEST TERMINAL	69	TEST0	TEST TERMINAL
20	AWRC	VCO OUTPUT TERMINAL FOR ACTIVE-WIDE RANGE PLL	70	TEST1	TEST TERMINAL
21	PVDD3	+3.3V POWER TERMINAL FOR PLL-EXCLUSIVELY	71	TEST2	TEST TERMINAL
22	PDOS	POSITION GAP SIGNAL OUTPUT TERMINAL OF EFM & PLCK SIGNALS	72	XVSS3	MICOM CLOCK DRIVING CIRCUIT GND TERMINAL
23	PDO	POSITION GAP SIGNAL OUTPUT TERMINAL OF EFM & PLCK SIGNALS	73	XI	MICOM CLOCK DRIVING CIRCUIT INPUT TERMINAL
24	TMAXS	TMAX DETECTION RESULT OUTPUT TERMINAL	74	XO	MICOM CLOCK DRIVING CIRCUIT OUTPUT TERMINAL
25	TMAX	TMAX DETECTION RESULT OUTPUT TERMINAL	75	XVDD3	MICOM CLOCK DRIVING CIRCUIT +3.3V POWER TERMINAL
26	LPFN	AMP REVERSE INPUT TERMINAL FOR LOW-PASS FILTER	76	DVSS3	D/A CONVERT R CHANNEL ANALOG GND TERMINAL
27	LPFO	AMP OUTPUT TERMINAL FOR LOW-PASS FILTER	77	RO	R CHANNEL AUDIO OUTPUT TERMINAL
28	PVREF	VREF(+1.65V) FOR PLL ONLY	78	DVDD3	DIGITAL/ANALOG CONVERT +3.3V POWER TERMINAL
29	VCOREF	VCO CENTER FREQUENCY BASE LEVEL VOLTAGE TERMINAL	79	DVR	DIGITAL/ANALOG CONVERT BASE VOLTAGE TERMINAL
30	VCOF	VCO FILTER TERMINAL	80	LO	L CHANNEL AUDIO OUTPUT TERMINAL
31	AVSS3	ANALOG GND TERMINAL	81	DVSS3	D/A CONVERT L CHANNEL ANALOG GND TERMINAL
32	SLCO	DATA SLICE GENERATING DIGITAL/ANALOG CONVERT OUTPUT TERMINAL	82	TEST3	TEST TERMINAL
33	RFI	RF SIGNAL INPUT TERMINAL	83	TEST4	TEST TERMINAL
34	AVDD3	ANALOG +3.3V POWER TERMINAL	84	BUS0	DATA INPUT TERMINAL FOR MICOM INTERFACE
35	RFCT	RERP SIGNAL INTERMEDIATE VOLTAGE	85	BUS1	DATA INPUT TERMINAL FOR MICOM INTERFACE
36	RFZI	INPUT TERMINAL FOR RERO ZERO CROSS	86	BUS2	DATA INPUT TERMINAL FOR MICOM INTERFACE
37	RFRP	RF RIPPLE SIGNAL INPUT TERMINAL	87	BUS3	DATA INPUT TERMINAL FOR MICOM INTERFACE
38	FEI	FOCUS ERRORSIGNAL INPUT TERMINAL	88	VDD5	DIGITAL 5V POWER SOURCE TERMINAL
39	SBAD	SUBBEAM ADDITION SIGNAL INPUT	89	VSS5	DIGITAL GND TERMINAL
40	TEI	TRACKING ERROR SIGNAL INPUT	90	/XRD	READ SIGNAL FOR MICOM INTERFACE
41	TEZI	TRACKING ERROR ZERO CROSS INPUT	91	/XWR	WRITE SIGNAL FOR MICOM INTERFACE
42	FDO	FOCUS EQ. OUTPUT TERMINAL	92	/XCM	FIRST WORD RECOGNIZE SIGNAL FOR MICOM INTERFACE
43	TRO	TRACKING EQ. OUTPUT TERMINAL	93	/XCE	MICOM INTERFACE CHIP ENABLE TERMINAL
44	VREF	ANALOG-BASED POWER(+1.65V)	94	TEST5	TEST MODE SELECT TERMINAL
45	RFGC	RF AMPLITUDE CONTROL SIGNAL OUTPUT TERMINAL	95	/RST	RESET INPUT TERMINAL
46	TEBC	TRACKING BALANCE CONTROL SIGNAL OUTPUT TERMINAL	96	/HSO	PLAY SPEED MODE FLAG OUTPUT TERMINAL
47	FMO	FEED EQ. OUTPUT TERMINAL	97	/UHSO	PLAY SPEED MODE FLAG OUTPUT TERMINAL
48	FVO	SPEED ERROR OR FEED EQ OUTPUT TERMINAL	98	/SHSO	PLAY SPEED MODE FLAG OUTPUT TERMINAL
49	DMO	DISK MOTOR EQ OUTPUT TERMINAL	99	EMPH	EMPHASIS FLAG OUTPUT TERMINAL OF SUBCODE QDATA
50	VSS3	DIGITAL GND TERMINAL	100	LRCK	CHANNEL CLOCK (44.1KHz) OUTPUT TERMINAL

• TA2119FN

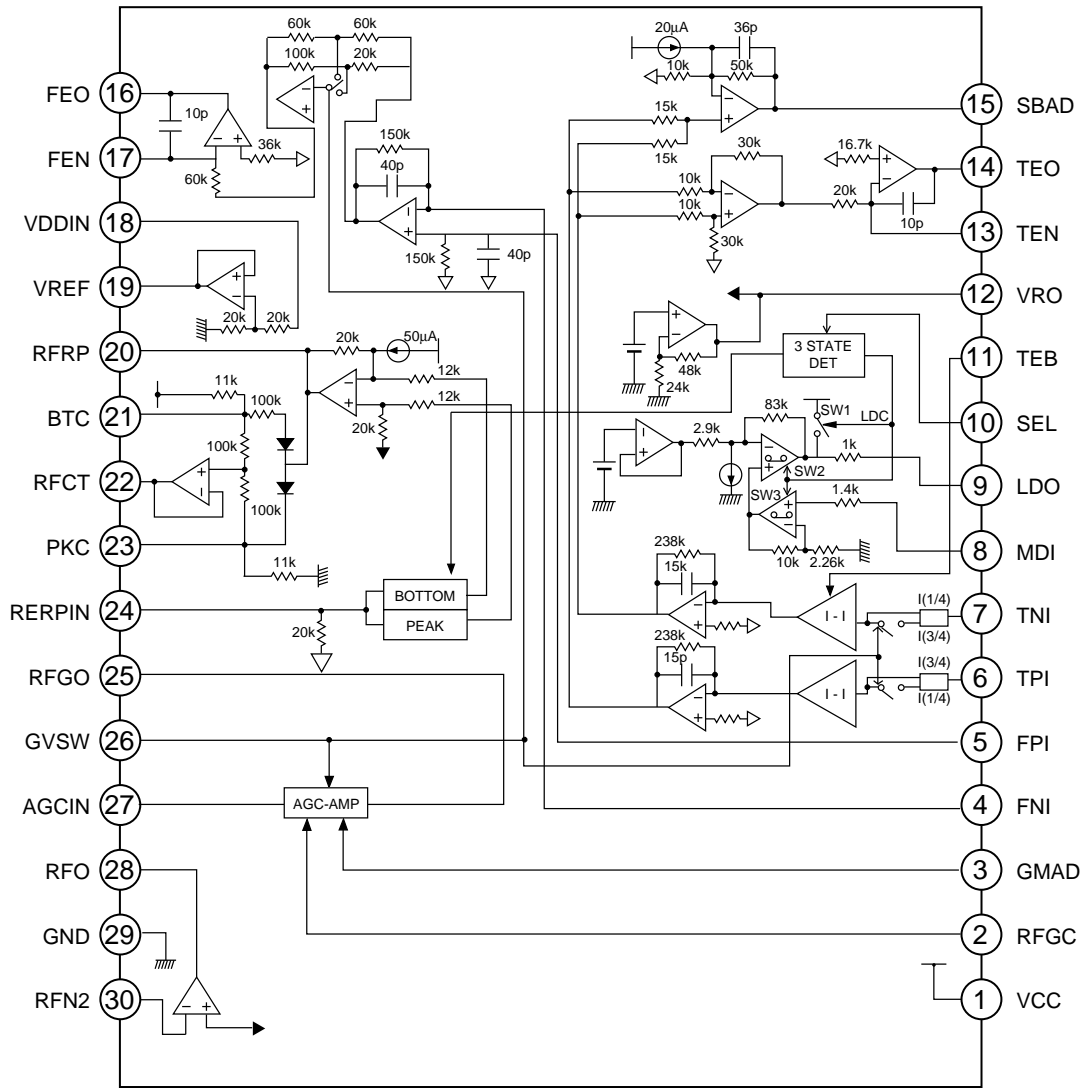

PIN DESCRIPTIONS

PIN NO	PIN NAME	FUNCTION
1	VCC	POWER SOURCE/VOLTAGE TERMINAL
2	RFGC	RF FREQUENCY CONTROL SIGNAL INPUT TERMINAL
3	GMAD	OPEN-LOOP GAIN CONTROL TERMINAL OF AGC AMP
4	FNI	MAIN BEAM AMP INPUT TERMINAL
5	FPI	MAIN BEAM AMP INPUT TERMINAL
6	TPI	SUB BEAM AMP INPUT TERMINAL
7	TNI	SUB BEAM AMP INPUT TERMINAL
8	MDI	MONITOR PHOTO-DIODE AMP INPUT TERMINAL
9	LDO	LASER DIODE AMP OUTPUT TERMINAL
10	SEL	INTERNAL GAIN AND SIGNAL SWITCH TERMINAL
11	TEB	TRACKING BALANCE CONTROL SIGNAL INPUT TERMINAL
12	VRO	STANDARD VOLTAGE RATING TERMINAL(VRO,2.1V)
13	TEN	TRACKING ERROR SIGNAL GENERATING AMP REVERSE INPUT TERMINAL
14	TEO	TRACKING ERROR SIGNAL GENERATING AMP OUTPUT TERMINAL
15	SBAD	SUB BEAM ADDITIONAL OUTPUT TERMINAL
16	FEO	FOCUS ERROR SIGNAL GENERATING AMP OUTPUT TERMINAL
17	FEN	FOCUS ERROR SIGNAL GENERATING AMP REVERSE INPUT TERMINAL
18	VDD	3.3V POWER SOURCE VOLTAGE TERMINAL
19	VREF	VOLTAGE RATING (VREF,1.6V) OUTPUT TERMINAL
20	RFRP	SIGNAL GENERATING AMP OUTPUT TERMINAL FOR TRACK COUNTER
21	BTC	RECT SIGNAL GENERATING BOTTOM DETECTOR CONTROL TERMINAL
22	RFCT	RFRP SIGNAL CENTER LEVEL OUTPUT TERMINAL
23	PKC	RFCT SIGNAL GENERATING PEAK DETECTOR CONTROL TERMINAL
24	RFRPIN	SIGNAL GENERATING AMP INPUT TERMINAL FOR TRACK COUNTER
25	RFGO	RF SIGNAL AMPLITUDE ADJUSTING AMP INPUT TERMINAL
26	GVSW	AGC,TE, FE AMP GAIN SWITCH TERMINAL
27	AGCIN	RF SIGNAL AMPLITUDE ADJUSTING AMP INPUT TERMINAL
28	RFO	RF SIGNAL GENERATING AMP OUTPUT TERMINAL
29	GND	GND TERMINAL
30	RFN2	RF SIGNAL GENERATING AMP INPUT TERMINAL

• KA3012D

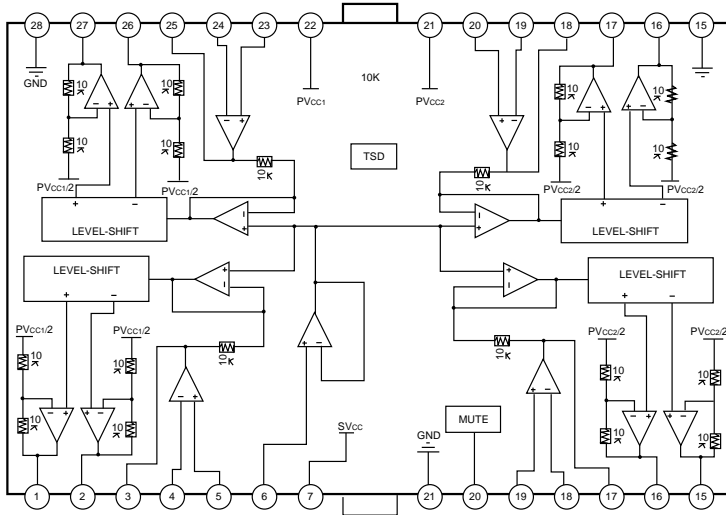

PIN DESCRIPTIONS

Pin No.	Symbol	I/O	Description
1	CH1-O	O	Drive CH1 Output(-)
2	CH1-O	O	Drive CH1 Output(+)
3	AMP1-O	O	OP-AMP CH1 Output
4	AMP1-I(-)	I	OP-AMP CH1 Input(-)
5	AMP1-I(+)	I	OP-AMP CH1 Input(+)
6	BIAS	I	Bias Input
7	SVCC	-	Supply Voltage(Signal)
8	GND	-	Ground
9	MUTE	I	Mute
10	AMP2-1(+)	I	OP-AMP CH2 Input(+)
11	AMP2-1(-)	I	OP-AMP CH2 Input(-)
12	AMP2-O	O	OP-AMP CH2 Output
13	CH2-O	O	Drive CH2 Output(+)
14	CH2-O	O	Drive CH2 Output(-)
15	GND	-	Ground
16	CH3-O	O	Drive CH3 Output(-)
17	CH3-O	O	Drive CH3 Output(+)
18	AMP3-O	O	OP-AMP CH3 Output
19	AMP3-I(-)	I	OP-AMP CH3 Input(-)
20	AMP3-I(+)	I	OP-AMP CH3 Input(+)
21	PVCC2	-	Supply Voltage(CH2&CH3)
22	PVCC1	-	Supply Voltage(CH1&CH4)
23	AMP4-I(+)	I	OP-AMP CH4 Input(+)
24	AMP4-I(-)	I	OP-AMP CH4 Input(-)
25	AMP4-O	O	OP-AMP CH4 Output
26	CH4-O	O	Drive CH4 Output(+)
27	CH4-O	O	Drive CH4 Output(-)
28	GND	-	Ground

• BA6849FP

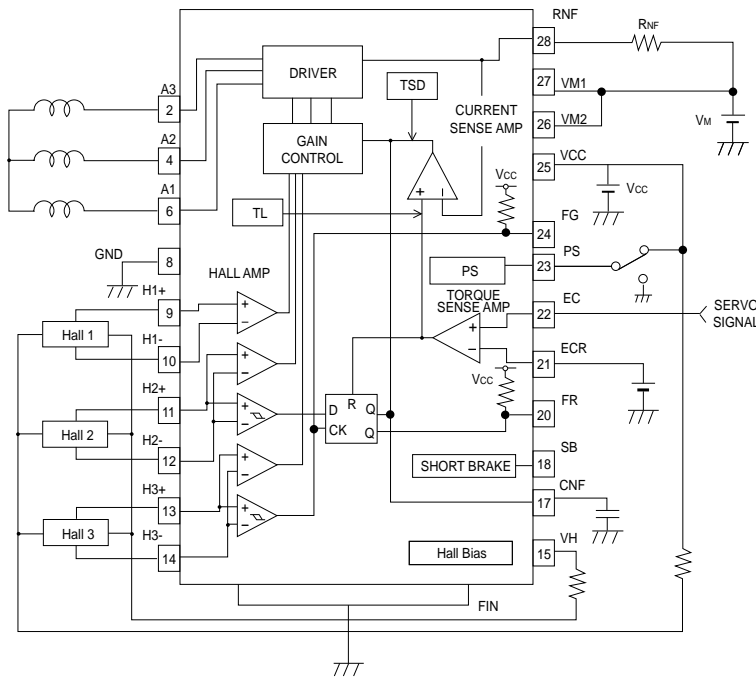

PIN DESCRIPTIONS

PIN NO.	PIN NAME	FUNCTION
1	N.C.	N.C
2	A3	Output3 for motor
3	N.C.	N.C
4	A2	Output3 for motor
5	N.C.	N.C
6	N.C.	N.C
7	A1	Output3 for motor
8	GND	GND
9	H1+	Hall input Amp1.positive input
10	H1-	Hall input Amp1.negative input
11	H2+	Hall input Amp2.positive input
12	H2-	Hall input Amp2.negative input
13	H3+	Hall input Amp3.positive input
14	H3-	Hall input Amp3.negative input
15	VH	Hall Bias
16	N.C.	N.C
17	CNF	Capacitor connection pin for phase compensation
18	SB	Short Brake terminal
19	N.C.	N.C
20	FR	Rotation detect terminal
21	ECR	Torque control standsrd voltage input terminal
22	EC	Torque control voltage input terminal
23	PS	START/STOP switch
24	FG	FG signal output terminal
25	VCC	Power supply for signal division
26	VM2	Power supply2 for driver
27	VM1	Power supply1 for driver
28	RNF	Power supply for driver division
FIN	FIN	GND

• **AT27PC512**

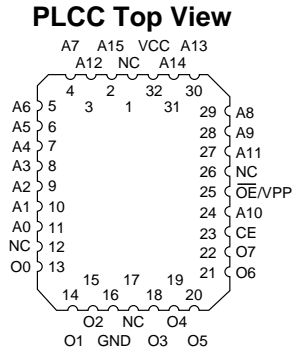

Pin Name	Function
A0-A15	Addresses
O0-O7	Outputs
\overline{CE}	Chip Enable
\overline{OE}/V_{pp}	Output Enable/Vpp
NC	No Connect

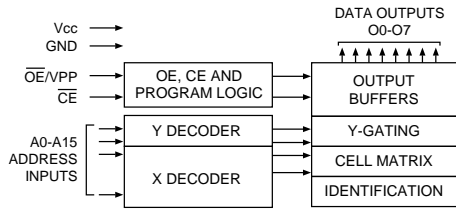

Mode/Pin	\overline{CE}	\overline{OE}/V_{pp}	Ai	Outputs
Read	V _{IL}	V _{IL}	Ai	D _{OUT}
Output Disable	V _{IL}	V _{IH}	X ⁽¹⁾	High Z
Standby	V _{IH}	X ⁽¹⁾	X	High Z
Pid Program ⁽²⁾	V _{IL}	V _{PP}	Ai	D _{IN}
GM Inhibit	V _{IH}	V _{PP}	X ⁽¹⁾	High Z
Duct Identification ⁽⁴⁾	V _{IL}	V _{IL}	A9=V _{IH} ⁽³⁾ A0=V _{IH} or V _{IL} A1-A15=V _{IL}	IdentificationCode

• **TC4S66F**

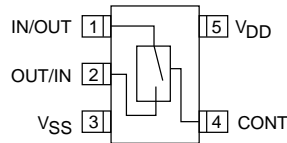
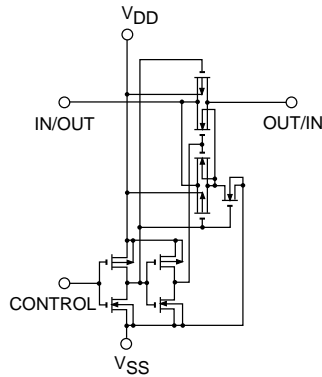

• **DAP 202K**

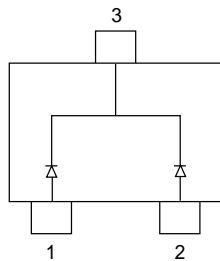

• **2SB 1132 (KTA 1664)**

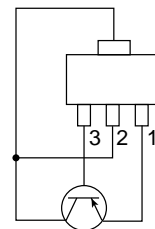

-TOP VIEW-

• NJM3414M

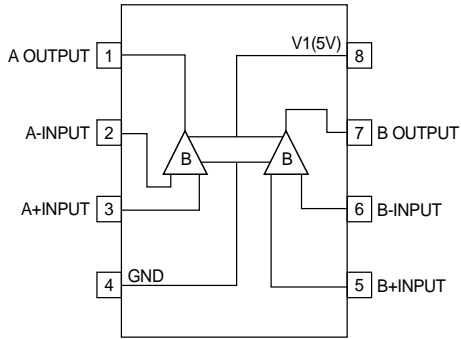

• KSC 1623 (2SC 2412K)

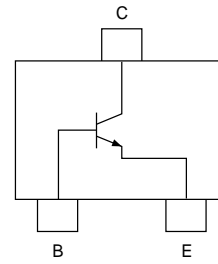

• GD74VHCT00

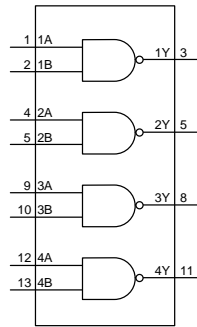
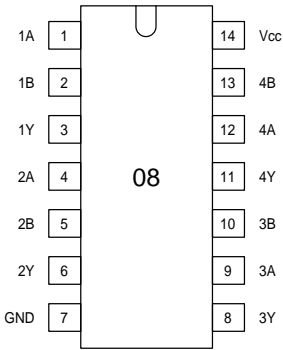

INPUTS		OUTPUT
nA	nB	nY
L	L	H
L	H	H
H	L	H
H	H	L

H=HIGH voltage level
L=Low voltage level

• XC61AC3502MR

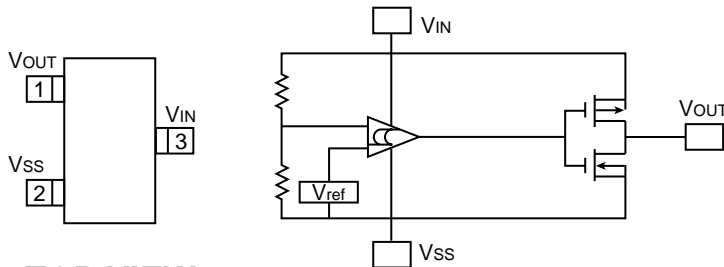

-TOP VIEW-

• MC74LS374DW

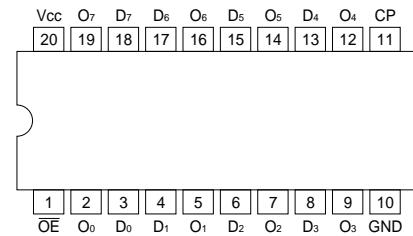

• PQ20VZ51

• Pin configuration

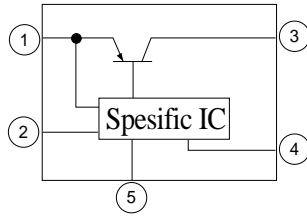
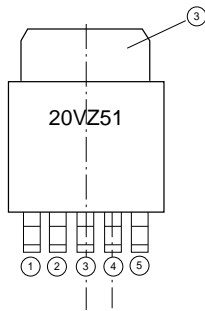

Pin No	Pin Name
①	DC input(VIN)
②	ON/OFF control terminal(VC)
③	DC output(VO)
④	Output voltage minute adjustment terminal(VADJ)
⑤	GND

